

CRACK DETECTION SYSTEM FOR RAILWAY TRACK BY USING ULTRASONIC AND PIR SENSOR

Prof. P.Navaraja
Assistant Professor,
Electronic and Communication Engineering,
Mahendra Institute of Technology,
Namakkal, Tamilnadu, India.

Abstract—In this project we introduced the integration of ultrasonic and total station for railway track geometry surveying system. this project consist of GPS module, GSM modem, IR sensor, PIR sensor for application of communication purpose, crack detection and finding of human being present in the railway track. The GPS module and GSM modem help us to find and sending railway geometric parameter of crack detection to nearest railway station. In the present of days we are using the measurement of track distance by using high cost LVDT with less accuracy, but we use the less cost ultrasonic sensor for above process with high accuracy. We implement PIR sensor in this project to avoid manual checking of detection of presences of human being in recent trends of application. The importance of this project is applicable both day and night time detection purpose.

Keywords— GPS module, GSM modem, IR sensor, PIR sensor, Ultrasonic distance meter.

I INTRODUCTION

Transport is very important to carry the passengers and goods from one place to another. The better transport leads to more trade. Economic level is mainly depends on increasing the capacity and level of transport. This paper presents an implementation of an efficient and cost effective solution suitable for railway application. In this paper we are going to use IR sensor to detect the crack in rail road, when the crack is detected its latitude and longitude values are send as a message to nearby station by using GPS and GSM service. Then Ultrasonic is used for the surveying process. Then other important component is PIR sensor it is used to detect the presence of humans in track.

II METHODS

2.1 Existing System

2.1.1 Composite Detection System

The composite detection system consists of a laser source, whose beam is collimated by a suited optic lens into a light plane, two 512X512 -pixel CCD cameras for complete optimum observation of the track, a digital processing system per camera, and a supervision system.

The laser beam focused by the cylindrical lens as a thin plane enlightens the upper part of the railway track orthogonally to the track surface. The intersection of the plane is therefore the

track profile (in the laser beam plane it is a two-dimensional line) which is observed by the CCD cameras. Each digital processing system performs real-time profile filtering and extraction (in the CCD camera geometrical coordinates) by using a composite approach from images of the corresponding CCD camera. Besides, the profile is approximately lying in a linear direction, i.e., cutting the image in stripes. Only one point of the profile belongs to each stripe. This characteristic allows for parallel processing since each stripe can be analyzed independently to reach 10 ms image processing time without affecting the profile accuracy.

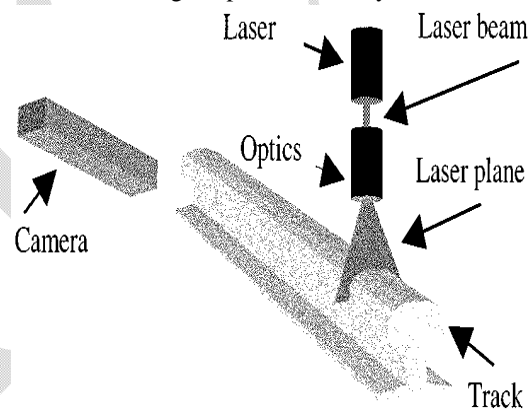

Fig 1: Detection System

In each column of the image localizing the position of the track profile means to find the position of the maximum laser reflection intensity. In the ideal case the intensity distribution along the column is Gaussian. Localizing the maximum implies therefore detecting the position of the expected Gaussian profile with the maximum likelihood.

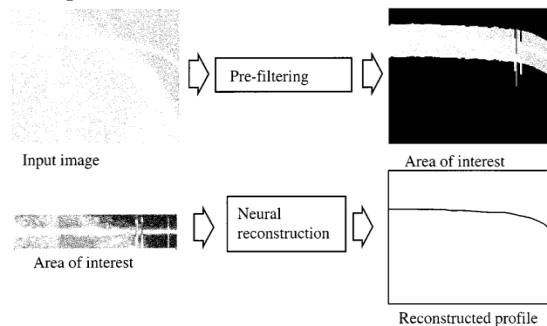

Fig 2: Neural Profile Reconstruction

To tackle this application, we tested both traditional filtering techniques with minimum-square approximation and neural network techniques. In the first case, results were quite poor due to the inability of capturing all nonlinearities and distortions. In the second case, the number of pixels to be processed in each column and the variety of the possible maximum light profile positions led to large inaccurate networks that are also difficult to train.

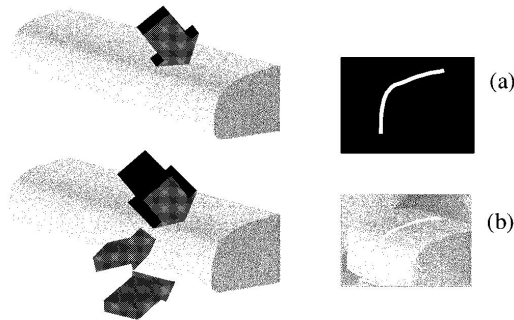

Fig 3: CCD images: (a) ideal and (b) real.

It is worth noting that highly approximate localization of the area of interest in each image is quite trivial for the human observer, even without experience. Track profile localization does not need to take into account all details in the whole column, but only the area around the maximum lighting. Experiments have shown that no information out of a 40-pixel strip centered approximately on the maximum lighting is necessary for accurate reconstruction of the track profile. Besides, this area of interest corresponds approximately to the zone around the highest-intensity Gaussian profile in the column. Such area can be easily found by identifying the maximum correlation of the light profile with the Gaussian reference: correlation can be effectively used. Finer localization of the maximum must deal with all nonlinearities presented above, which are difficult to be captured algorithmically while they are easily described by examples. In the literature, neural networks were proved effective for this kind of task.

The Disadvantages of existing system are noise in input images, cost is high, and output is not accurate.

2.1.2 Crack Detection using Rayleigh wave-like wideband guided Ultrasonic waves

Ultrasonic inspection of rails is usually restricted to low speeds of around 20-30mph, which limits the viability of testing many tracks regularly. Furthermore many of the most serious defects that can develop in the rail head can be very difficult to detect using the currently available inspection equipment. One of the reasons for slow inspection speeds using conventional NDT is the need for coupling between the transducer and the track using either liquid or dry coupling materials. EMATs have been used 2,3 or suggested 4 to measure both rail tracks and wheels by other workers and the use of non-contact ultrasonic measurements are still being investigated by a number of international research groups.

In this method we discuss the use of EMATs on rail for longitudinal and transverse crack defect detection and depth gauging. Ultrasonic surface waves that are similar in behaviour to Rayleigh waves are an obvious candidate for surface breaking crack detection. If a defect lies between the Rayleigh wave generator and detector then it will to some degree block the Rayleigh wave. The amplitude of a Rayleigh wave displacement decays with depth into the sample and most of the energy associated with a particular frequency lies within a depth equal to one wavelength at that frequency. Almost all of the energy lies within a depth corresponding to two wavelengths.

The different frequency components will effectively probe to different depths below the sample surface. In a measurement where we attempt to propagate a Rayleigh wave through a region containing a surface breaking crack, the crack depth can be estimated by the amount of Rayleigh wave energy or amplitude that is transmitted through or underneath that region. Closed or partially closed cracks can obviously complicate the analysis and increase the amount of Rayleigh wave energy transmitted through the crack compared to an open crack.

2.1.3 Electromagnetic acoustic transducer (EMAT)

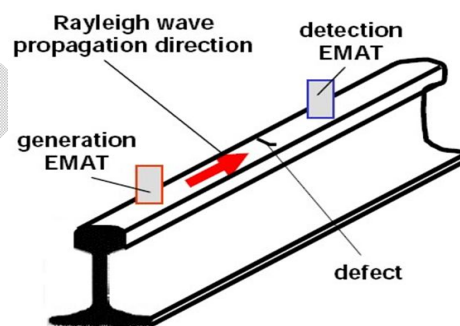

Fig 4: Schematic diagram shows how the EMATs were used in pitch-catch type geometry for propagation of Rayleigh waves down the length of the rail head to measure and detect transverse cracks.

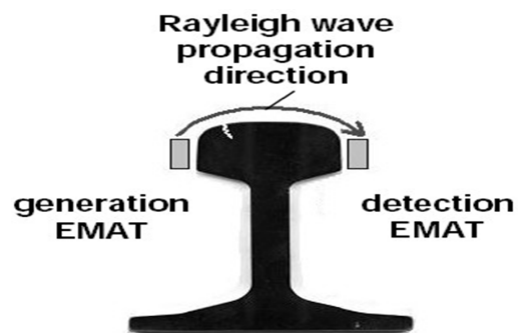

Fig 5: Schematic diagram shows how the EMATs were used in pitch-catch type geometry for propagation of Rayleigh waves around the rail head to measure and detect longitudinal cracks.

The EMATs used in this paper have been designed and built in the Department of Physics at the University of Warwick 13. In our initial tests we have used pitch-catch type geometry where one EMAT generates a Rayleigh wave that propagates down the length of the sample as shown in figure 1 or around the rail head as shown in figure 2, to be detected by a second EMAT. The EMATs are held fixed relative to each other providing a constant path difference between them on a flat surface.

2.2 Proposed System

In proposed system our project are detect the rail road crack, measuring distance for two rail road and also measure the pursuing human in the railway track. when IR sensor are used for detect the crack in the track and ultrasound sensor measure the distance between the two track and also PIR sensor are used to detect human being pursuing in the track. If any crack are occurred in the track means longitude and latitude of the place are messaged to the nearest station and ultrasonic sensor are measure the distance between the two track if any small variance means they detect and message to the nearest station using GPS and GSM modem. when PIR sensor are detect the human being and animals on the railway track, if any one pursuing on the track means they stop the surveying work after crossing rail road they are detect the track.

III DESIGN

The three main components used in the block is IR sensor, Ultrasonic, PIR sensor. IR sensor is used to detect the crack in railway track. Infrared (IR) transmitter is one type of LED which emits infrared rays generally called as IR Transmitter. Similarly IR Receiver is used to receive the IR rays transmitted by the IR transmitter. One important point is both IR transmitter and receiver should be placed straight line to each other.

When the signal is received by the receiver then it is taken as crack is detected. When the crack is detected the latitude and longitude value is send as a message to nearby station. Passive Infra-Red sensors (PIR sensors) are electronic devices which measure infrared light radiating from objects in the railway track. PIRs are often used in the construction of *PIR-based motion detectors*. Ultrasonic wave is used to measure the track distance. Then the LCD display is used to view the result.

3.1 Required Components

3.1.1 Microcontroller: ATmega162

The ATmega162 is a low-power CMOS 8-bit microcontroller based on the AVR enhanced RISC architecture. By executing powerful instructions in a single clock cycle, the ATmega162 achieves throughputs approaching 1 MIPS per MHz allowing the system designed to optimize power consumption versus processing speed.

3.1.2 GPS

GPS stands for Global Positioning System. The GPS is used to receive the position data from the vehicles and display on a digital map. It too will have the interface to the communication link. Enhanced features include video features, trace mode, history track, vehicle database, network support.

3.1.3 GSM module

The GSM net used by cell phones provides a low cost, long range, wireless communication channel for applications that need connectivity rather than high data rates. It is used to send the SMS to mobile phone.

3.1.4 IR sensor

Infrared transmitter is one type of LED which emits infrared rays generally called as IR Transmitter. Similarly IR Receiver is used to receive the IR rays transmitted by the IR transmitter. One important point is both IR transmitter and receiver should be placed straight line to each other.

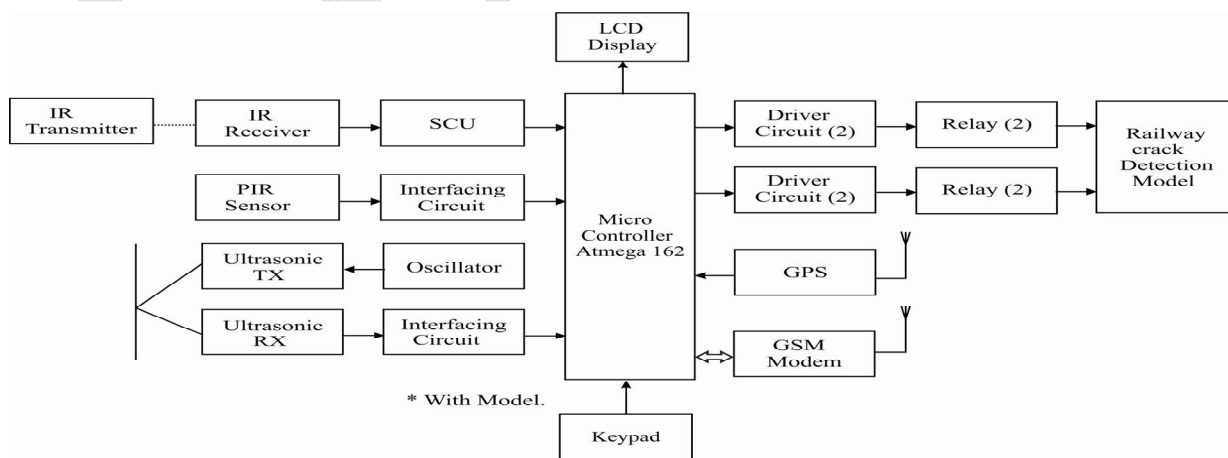

Fig 6: Block Diagram

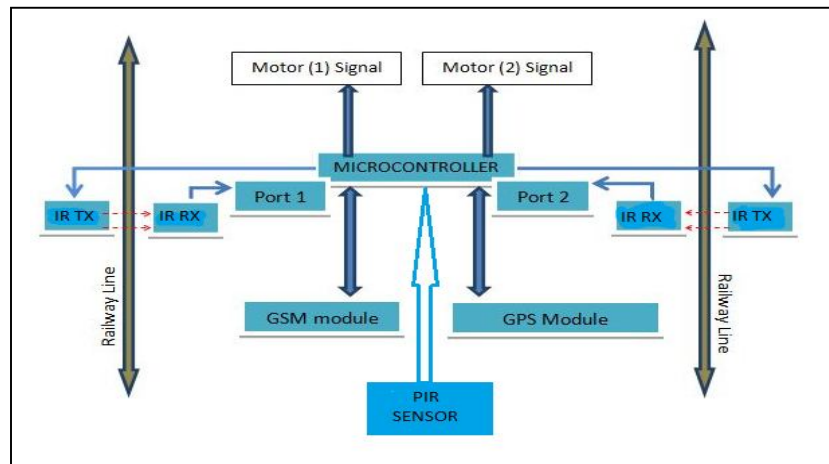

Fig 7 : Working Diagram

3.1.5 Passive Infrared Sensors (PIR)

Passive Infra-Red sensors (PIR sensors) are electronic devices which measure infrared light radiating from objects in the field of view. PIRs are often used in the construction of PIR-based motion detectors, see below. Apparent motion is detected when an infrared emitting source with one temperature, such as a human body, passes in front of a source with another temperature, such as a wall.

3.1.6 DC Motors

To traverse a distance of 22 Km in 4 hrs, an average speed of 1.5 meters/sec is needed. The proposed design uses 4 DC motors. DC motor works according to relay operation.

- When relay 1 is in the ON state and relay 2 is in the OFF state, the motor is running in the forward direction.
- When relay 2 is in the ON state and relay 1 is in the OFF state, the motor is running in the reverse direction.

3.1.7 Workings

The proposed crack detection scheme has been tested by placing the robot on an actual rail track. The latitude, longitude and the nearest railway station will be sent as a message.

distance meter will verify the distance between two tracks. When the human or animal is on the track the PIR sensor will detect the presence and stop the checking process till they move on. After they moved on the track it will continue the process.

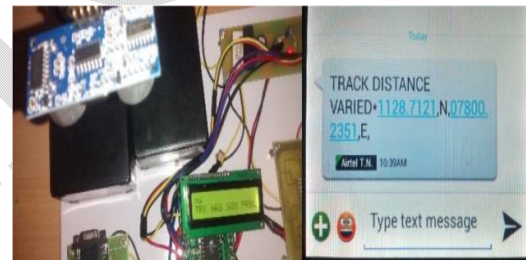

Fig 8: Distance Measurement using Ultrasonic distance meter

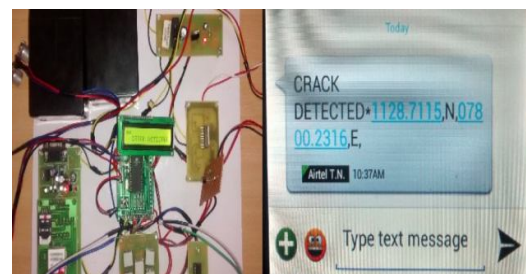

Fig 9: Crack Detection using IR Sensor

IV RESULT

When the crack is detected on the track the text message is sent to the preferred number by using the GSM and GPS service. The text message contains the latitude and longitude value of the place where the crack is detected. The ultrasonic



Fig 10: Human Detection using PIR Sensor

V CONCLUSION

In this paper, we have presented the IR sensor based railway crack detection system and PIR sensor based presence of human detection system. The crack can be detected without only error. It does not give false output. The idea can be implemented in large scale in the long run to facilitate better safety standards for rail tracks and provide effective testing infrastructure for achieving better results in the future.

References

- [1] Qiao Jian-hua, Li Lin-sheng and Zhang Jinggang, "Design of Rail Surface Crack-detecting System Based on Linear CCD Sensor", IEEE Int. Conf. on Networking, Sensing and Control, 2008.
- [2] K. Vijayakumar, S.R. Wylie, J. D. Cullen, C.C.Wright, and A.I. AISHamma'a, "Non invasive rail track detection system using Microwave sensor", Journal of App. Phy., 2009.
- [3] M. Cacciola, G. Megali, D. Pellicano, S. Calcagno, M. Versaci, and F. C. Morabito, "Rotating Electromagnetic Field for Crack Detection in Railway Tracks", PIERS ONLINE , Vol. 6, NO. 3, 2010.
- [4] Wojnarowski, Robert John Welles, Kenneth Brakeley Kornrumpf, and William Paul, "Electromagnetic system for railroad track crack detection and traction enhancement".
- [5] Richard J. Greene, John R. Yates and Eann A. Patterson, "Crack detection in rail using infrared methods", Opt. Eng. 46, 051013, May 2007.
- [6] Hartman, G.A., "Infrared Damage Detection System (IDDS) for real time, small-scale damage monitoring, Charlotte, North Carolina (2003).